



GUIDE FOR TESTING POWER TRANSFORMERS

Routine test

INDEX

| | |
|---|-----------|
| Introduction..... | 3 |
| <i>1 Dielectric tests – Separate-source voltage withstand test</i> | 4 |
| <i>2 Induced voltage test.....</i> | 5 |
| <i>3 Voltage ratio measurement and check of polarities and connections</i> | 6 |
| <i>4 No-load current and no-load loss measurement.....</i> | 7 |
| <i>5 Winding resistance measurement.....</i> | 8 |
| HV winding resistance measurement..... | 8 |
| LV winding resistance measurement..... | 8 |
| <i>6 Short-circuit impedance and load loss measurement</i> | 9 |
| <i>7 Partial discharge measurement</i> | 10 |

Introduction

The following routine tests must be carried out on all power transformers :

- separate-source voltage withstand test
- induced voltage test
- voltage ratio measurement and check of polarities and connections
- no-load current and no-load loss measurement
- winding resistance measurement
- short-circuit impedance and load loss measurement
- partial discharge measurement

in accordance with the International Basic Standards IEC 60726 for Dry-type power transformers

1 Dielectric tests – Separate-source voltage withstand test

The single-phase applied voltage wave shape shall be approximately sinusoidal. The test must be performed at rated frequency. At the end of the test, the test voltage shall be rapidly reduced up to 1/3 the full voltage before disconnection. The full test voltage shall be applied for 60 seconds between the winding under test and all the remaining windings, magnetic core, frame and enclosure connected to earth. The test shall be performed on all the windings. The test is successful if no failure occurs at full test voltage.

CONNECTION SCHEME:

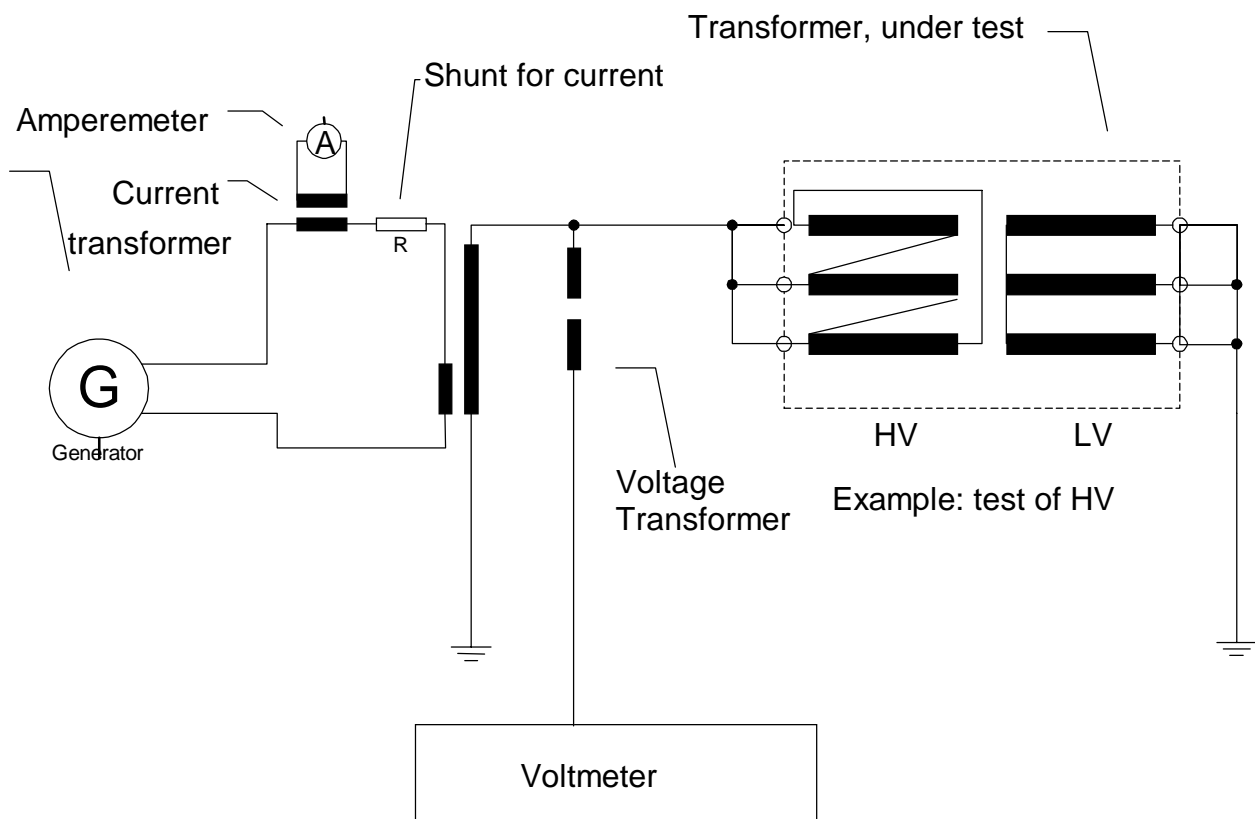

2 Induced voltage test

The test voltage shall be twice the value corresponding to the rated voltage; it shall be applied between the terminals of the secondary windings, by maintaining the primary winding open. The duration of the test at full voltage shall be 60 s, and the frequency twice the rated value. The test shall start with a voltage lower than 1/3 the full test voltage, and it shall be quickly increased up to full value. At the end of the test, the voltage shall be rapidly reduced up to 1/3 the rated value before disconnection. The test is successful if no failure occurs at full test voltage.

CONNECTION SCHEME:

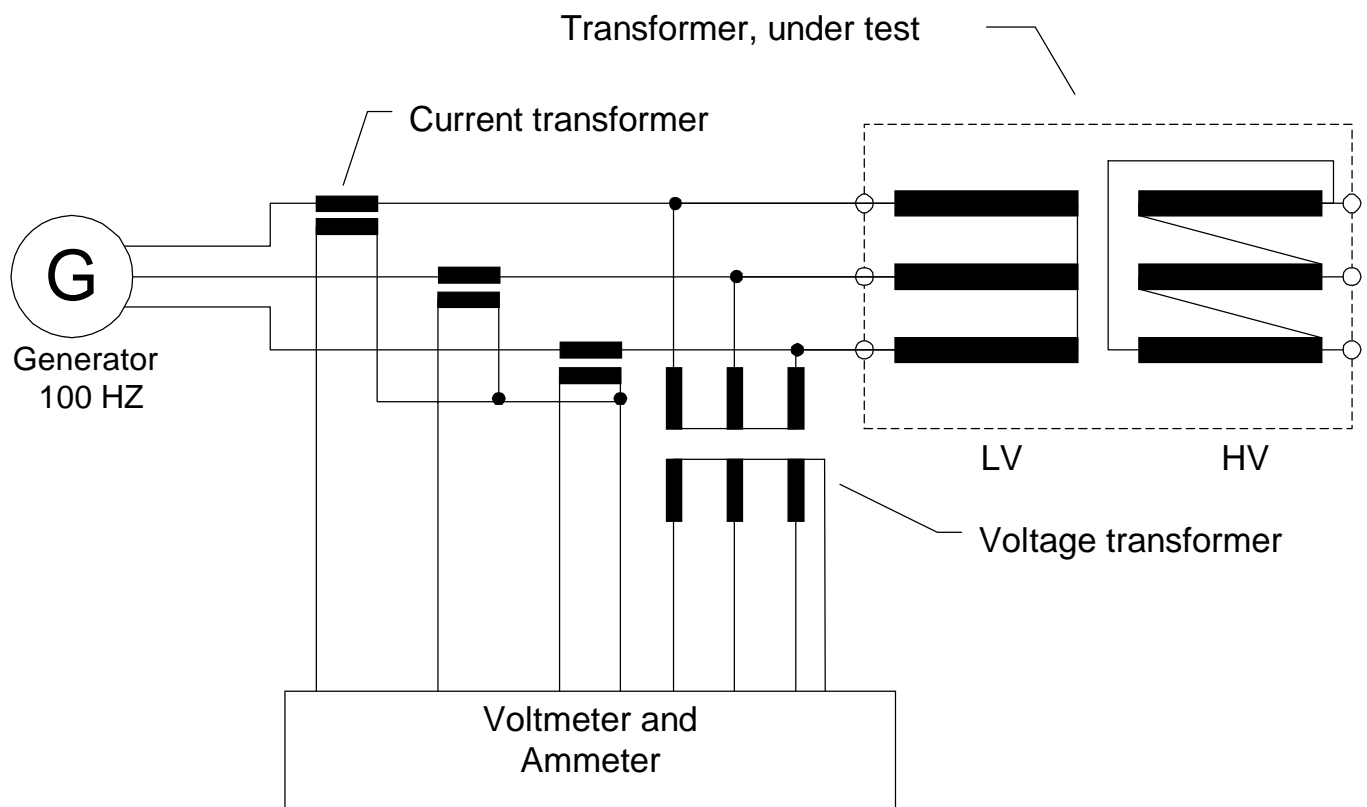

3 Voltage ratio measurement and check of polarities and connections

Voltage ratio measurement and check of polarities and connections shall be performed on all tap-changer positions; the correspondence between the numbers assigned to the tapplings and the ratings shall also be checked. Voltage ratio measurement shall be performed phase by phase between the terminals of corresponding windings. Voltage ratio measurement is carried out by use of potentiometric method.

CONNECTION SCHEME:

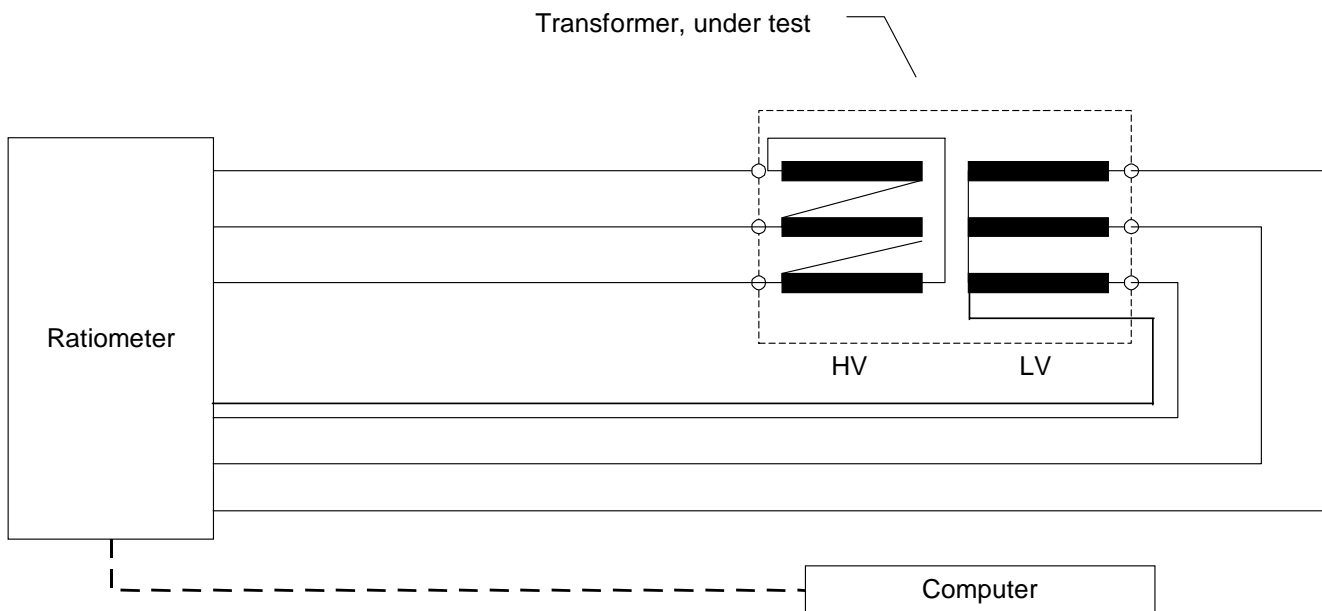

4 No-load current and no-load loss measurement

This test is performed by supplying LV windings at rated frequency and rated voltage. The wave shape shall be as nearly as possible of the sine-wave and the primary windings shall be open. The frequency of the test shall not differ from the rated value more than $\pm 1\%$. No-load current and loss shall be measured as well as the mean value and the effective value of the voltage. If these two readings are equal, no correction shall be applied on the measurement of no-load loss; otherwise, no-load loss shall be referred to sine-wave condition in accordance with IEC Standards 60076-1. No-load current shall result as the average value of three readings performed by effective value ammeters. Three wattmeters shall be used to measure the power, by using instrument transformers and transducers when necessary.

CONNECTION SCHEME:

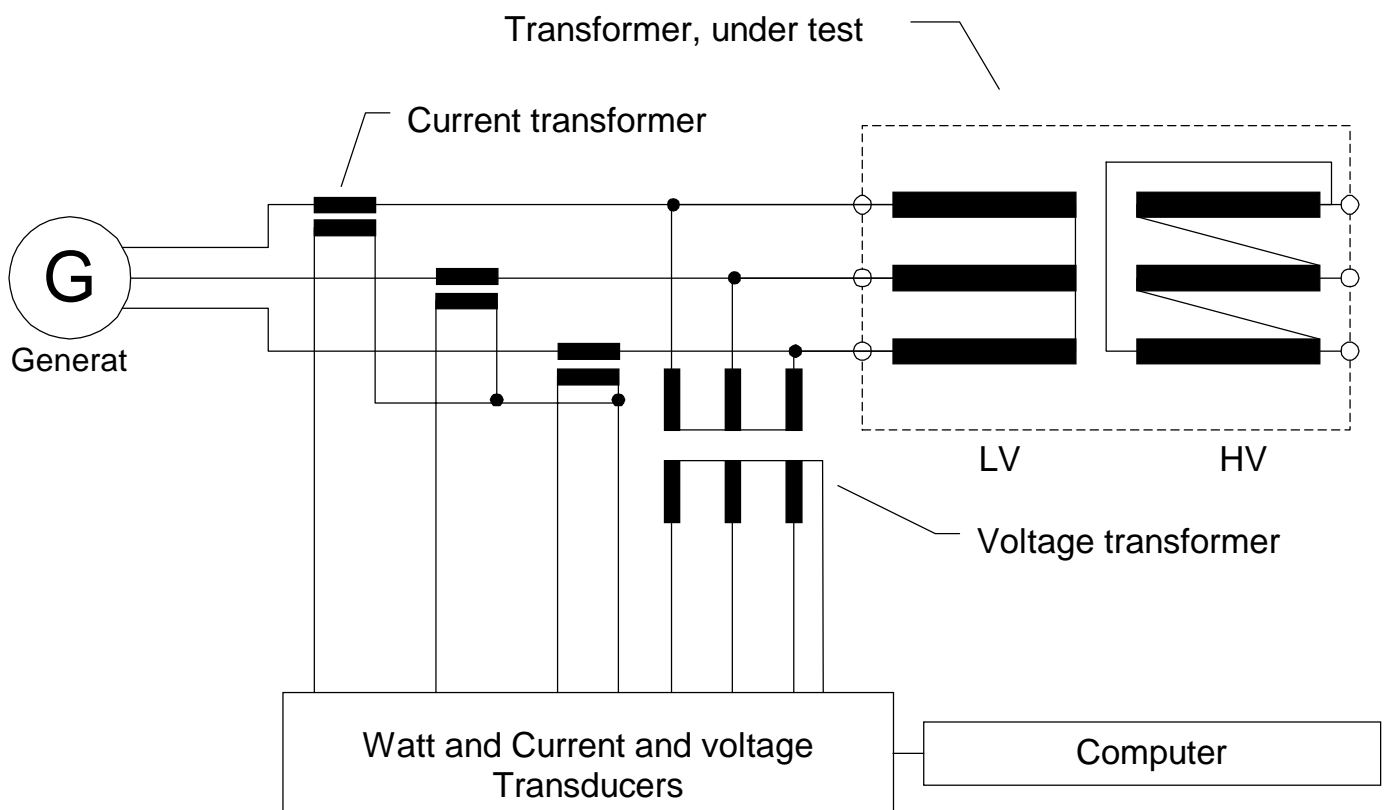

5 Winding resistance measurement

Winding resistance measurement shall be performed when the windings are at ambient temperature without supply for a time long enough to achieve this condition. The measurements shall be carried out in direct current between terminals according to the sequence U-V; V-W; W-U.

Ambient temperature shall also be measured. It shall result as the average value of three measurements performed by apposite thermal sensors.

HV winding resistance measurement

HV winding resistance measurement shall be performed by measuring simultaneously voltage and current. The voltmeter and ammeter must be connected as follows :

- voltmeter terminals must be connected beyond current cables;
- the current shall not exceed 10% of winding rated current;
- the measurement shall be carried out after voltage and current are stable.

Unless otherwise agreed, the HV winding shall be connected on principal tapping.

LV winding resistance measurement

LV winding resistance measurement shall be performed by measuring simultaneously voltage and current. The voltmeter and ammeter shall be connected as follows :

- voltmeter terminals shall be connected beyond current cables;
- the current shall not exceed 5% of winding rated current;
- the measurement shall be carried out after voltage and current are stable.

CONNECTION SCHEME:

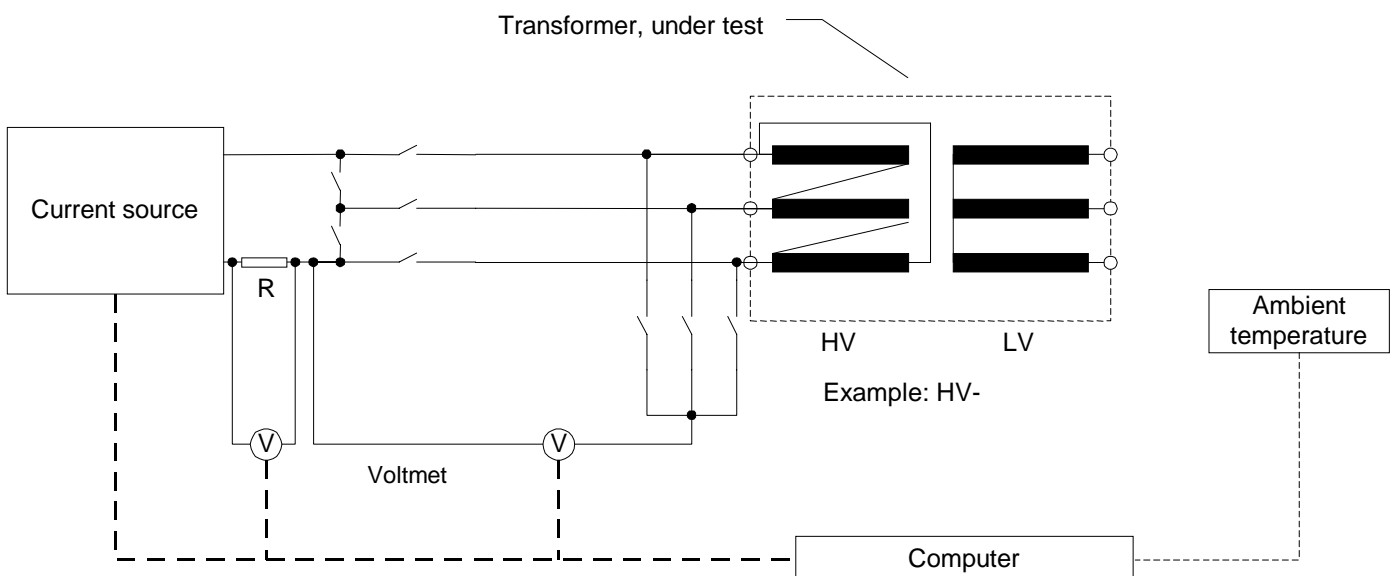

6 Short-circuit impedance and load loss measurement

Short-circuit impedance and load loss measurement shall be performed at rated frequency, by applying on the transformer primary windings (connected on principal tapping) a three –phase sine-wave voltage system. The secondary windings shall be short-circuited. Applied voltage, current and load loss shall be measured.

The frequency of the test shall not differ from the rated frequency more than $\pm 1\%$. In case the rated power is higher than 1000 kVA, load loss shall be measured by using three wattmeters, in order to reduce measurement uncertainties. When necessary, instrument transformers and transducers shall be used. The measured values shall be referred to rated current and then calculated at reference temperature. This temperature is the annual average ambient temperature (20°C) increased by the permissible temperature rise in accordance with the temperature class of the windings. IEC 60726 specify the permissible temperature rises on table no. 4. Beside, IEC 60076-1 give a complete explanation of how to perform the carries at rated current and at reference temperature.

CONNECTION SCHEME:

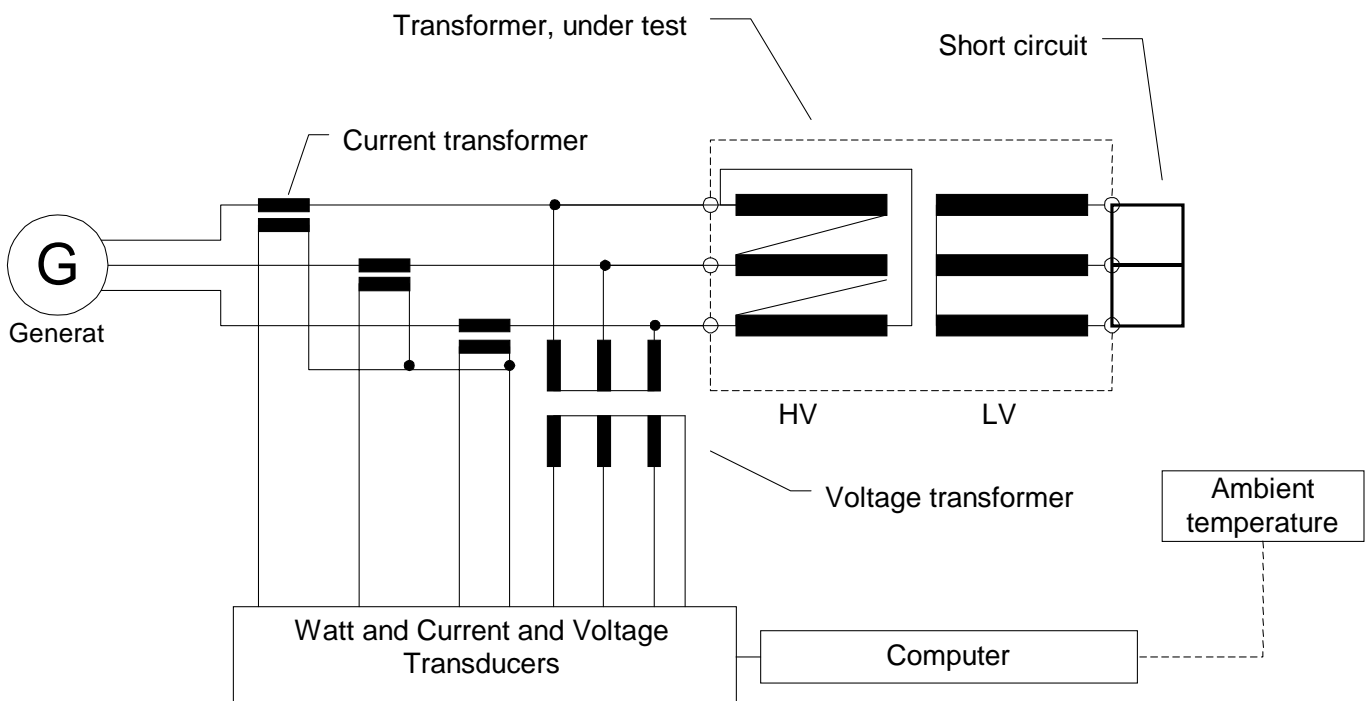

7 Partial discharge measurement

A basic measuring circuit for partial discharge test is shown in figure 2 , IEC Standards 60726. The low-voltage windings shall be supplied from an alternate 100 Hz voltage source. The voltage shape shall be as nearly as possible of the sine-wave. Unless otherwise specified, a pre-stress voltage of $1,5 U_m$ shall be induced for 30 s, followed without interruption by a voltage of $1,1 U_m$ for three minutes, during which the partial discharge level shall be measured. The calibration of the measuring circuit is carried out by injecting simulated discharge pulses of 100pC at transformer terminals. Partial discharge measurement shall be carried out by use of an oscilloscope, in order to analyse the developing of the ongoing phenomena. Test procedures must be in accordance with IEC Standards 60726. The test is successful if the partial discharge level is lower than 20 pC unless otherwise agreed between manufacturer and purchaser.

CONNECTION SCHEME:

