

ENCLOSED SINGLE PHASE VARIABLE TRANSFORMERS INSTALLATION AND SAFETY INSTRUCTIONS

Manufactured to BS 7452 / IEC 989



1. Read all of these instructions before you use the transformer
2. This variable autotransformer is not designed to provide mains isolation
3. Variable autotransformers operate at mains voltages
DO NOT EXCEED THE MAXIMUM VOLTAGE AND CURRENT RATINGS
4. Connection and maintenance should only be carried out by suitably qualified personnel
Note: Remove the protective packing disc from the carbon brush before use
5. The input lead to the unit should be either hard wired to an enclosed mains source or fitted with a suitable rated plug.
6. The output lead should be either hard wired inside the equipment it is to operate or wired to a suitable socket.
7. The terminal marked "C" is a common neutral for both the supply input and the load output.
8. The load must always be connected across the output, "E" and "C" terminals, **NEVER** connect the load in series with the transformer
9. The centre tap "D" terminal is for operation in a Buck-Boost configuration not 110V to 120V input supply operation
10. Carbon brushes should be inspected for damage and wear, faulty and worn brushes **will** result in damage to the transformer winding.
11. These units are Class 1 insulated and must not be tested on Portable Appliance Testers (PAT) as Class 2 double insulated products. Flash test only at 2.0KV. Flash test only between Earth and Live **DO NOT** flash test between input and output

WIRING INSTRUCTIONS

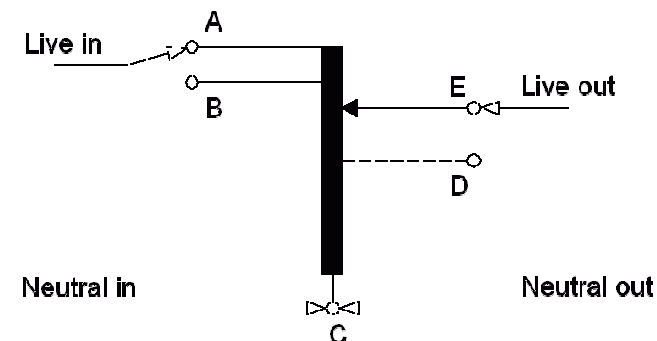

Connection "D" is only present on units rated 5 Amps and higher for Buck-Boost applications.

Input "C" and "A" Output 0 – 100% of input

Input "C" and "B" Output 0 – 112% of input

Output Neutral "C" and Live, wiper arm contact, "E"

Model	Output	Style	A	B	C	D	E	Ø
CMV2E-1	2A	A	160	130	46	123	32	4
CMV3E-1	3A	A	160	130	46	123	32	4
CMV5E-1	5A	B	175	146	30	115	35	11
CMV8E-1	8A	B	175	146	30	135	35	11
CMV10E-1	10A	B	175	146	30	135	35	11
CMV15E-1	15A	B	220	176	37	148	42	11
CMV20E-1	20A	B	220	176	37	148	42	11
CMV28E-1	28A	B	276	238	80	177	43	13

